

# TECHNICAL INSTRUCTIONS

SANMERA

## 1. Mixing-desks:

K1	Kick	AKG D 112, SH 409	K13	Keyboard R	D.I.
K2	Snare	SM 57	K14	Vocal Lead (Voc1)	SM 58 / BD M 700
K3	Timbales L	C 535 EB, C 451 E	K15	Vocal Lead (Voc2)	SM 58 / BD M 700
K4	Timbales R	C 535 EB, C 451 E	K16	Vocal (Voc3)	SM 58 / BD M 700
K5	Bell	SM 57	K17	Vocal (Voc4)	SM 58 / BD M 700
K6	Overhead	C 535 EB, C 451 E	K18	Vocal (Voc5)	SM 58 / BD M 700
K7	Conga links	SM 57 / MD 409	K19	Tenor Sax (TS)	SM 58 / BD M 700
K8	Conga mitte	SM 57 / MD 409	K20	Alto Sax (AS)	Pickup-Phantom/Funk <sup>1)</sup>
K9	Conga rechts	SM 57 / MD 409	K21	Trumpet (TRP)	Pickup-Phantom/Funk <sup>1)</sup>
K10	Bass	D.I.	K22	Trombone (TB)	Pickup-Phantom/Funk <sup>1)</sup>
K11	E-Bass	D.I.	K23		
K12	Keyboard L	D.I.	K24		

The listing for the detailed instruments are only sketched. The sequence of numbers for the mixing desk might vary according to the preference of the sound technician at the place of performance. The miking of the drum kit can be adjusted by the sound technician according to local preference. The instruments marked with <sup>1)</sup> are to be provided by the artist(s).

## 2. Stage-set:

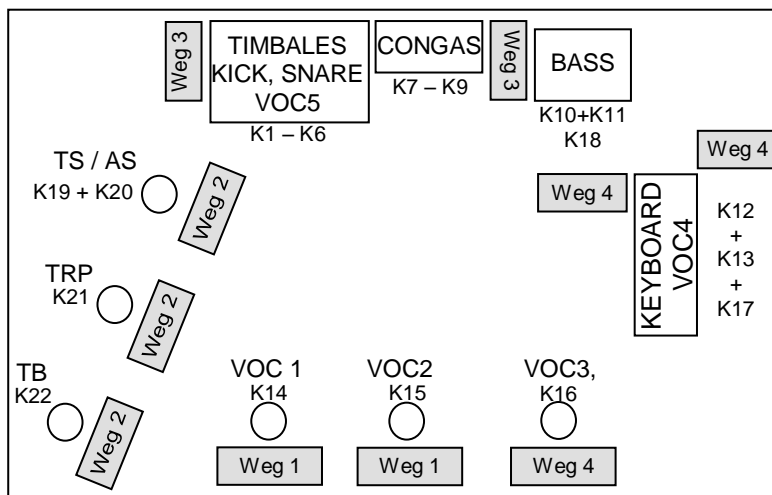

Size of Stage: Minimum 7x4 meters.

## 3. Monitor- System:

To assure sufficient monitoring (4) four ways of monitoring (see sketch: Monitors 1-4) are to be provided.

Monitor-Default-Mix:  
 (+ ... emphasize)

Way1: **Voc1-2+**, Voc3-5, Piano

Way2: **SAX+**, **TRP+**, **TB+**, **FL+**,  
 Voc1-6, Bass, Piano

Way3: Voc1-5, Timbales L+R,  
 Congas, Piano, SAX, TRP, TB

Way4: **Voc3-5+**, Voc1-2, Piano,  
 SAX, TRP, TB

**4. PA-System:** PA has to be adjusted to space according to its original capacity by the sound technician.

**5. Mixing-desk:** Min: 22 channles,  
 5 aux. channles, 8 subgroup

**6. Effects:** 2 x 27 band graphic EQ for main output L & R, 1 stereo-reverb, min. 15 band EQs for each monitoring way

The above technical instructions are a major part of the contract. If there are any difficulties with the technological part to be expected, the Event Organizer is obliged to report them to the SANMERA without delay, to find workable alternatives for both parties. We recommend to download the actual rider right before the concert, to be up to date.

....., the.....  
 Event Organizer